

# Wide Mouth Outlet (WMO) Installation Instructions

(Fasteners not included)

**Note:** Use of screws for connecting Wide Mouth and downspout piping is a common practice, however Raindrop® recommends the use of pop-rivets whenever possible because of the lower profile and decreased chances of debris being snagged over time by a screw tip inside the gutter or downspout.

**Tools Needed:**

Tin Snips, Tape Measure, Hand Sealers, Rivet Gun, 1/8" rivets, Drill, 1/8" drill bit, Pencil, Caulk Gun.

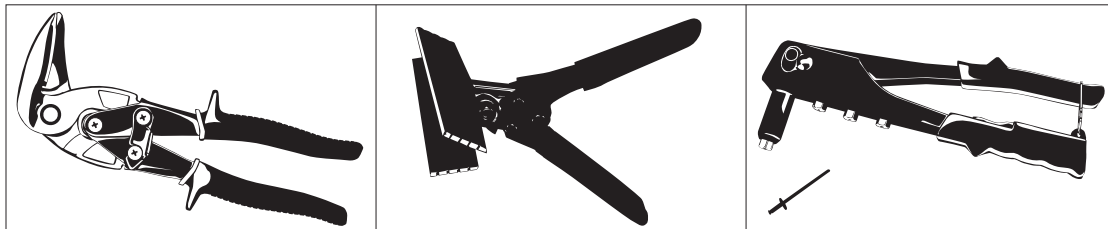

## Step 1 Gutter Outlet Preparation

- 1.1 - New Gutters: Punch/cut a regular size outlet hole [1].  
Existing Gutters: Remove any caulk and fasteners holding the outlet cup in place. Cut and pull until outlet can be removed [1].
- 1.2 - Mark two outside edge lines at 90° [2,3] centered over outlet hole [1].  
(5 inch gutter = lines are 5.5 inches apart)  
(6 inch gutter = lines are 6.25 inches apart)
- 1.3 - Mark lines from opening to each corner and cut [4].
- 1.4 - Bend all four flaps straight downward [5]. *Bend along line.*
- 1.5 - Trim rough edges off of all flaps [6]- leave flaps a minimum of 1/2 inch from gutter floor.

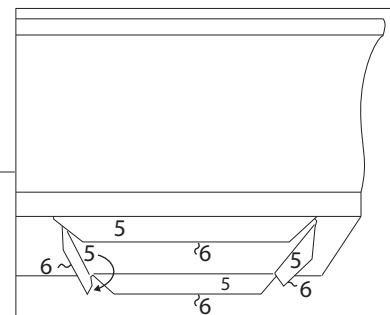
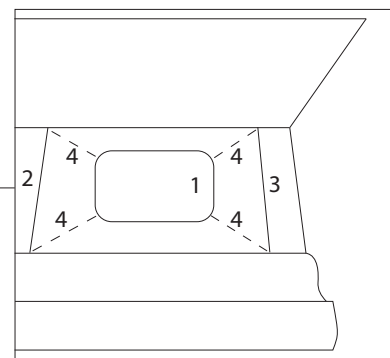

## Step 2 Prepare Wide Mouth

- 2.1 - Temporarily hold downspout pipe under and on to the Wide Mouth bottom and mark all four corners [7] where pipe hits Wide Mouth. *\*Use dimples on Wide Mouth as a guide/reference. Not all downspouts are the same.*
- 2.2 - Separate pipe and Wide Mouth, then cut all four corners along the bend [8] from bottom [9] of Wide mouth up to your marks [7].
- 2.3 - Bend these flaps outward slightly past straight down [10]. *Bend along line.*

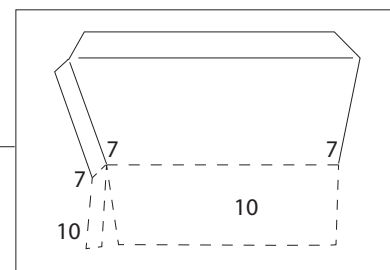
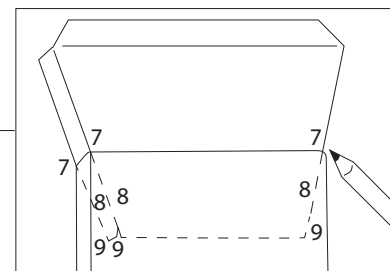

# Wide Mouth Outlet (WMO) Installation Instructions

Continued

## Step 3 Install Wide Mouth

- 3 - Position Wide Mouth centered under gutter opening so it is tight to the gutter floor [11].  
(Wide Mouth front [12] and back [15] to be outside of the gutter, Gutter flaps [5] to be inside of Wide Mouth sides.)
- 3.2 - Secure back of Wide Mouth with a fastener through back of gutter [14] from the inside of the gutter and in an area that will also penetrate the rear flange portion of the Wide Mouth [15].
- 3.3 - Secure front of Wide Mouth to gutter with a pop-rievet [13].

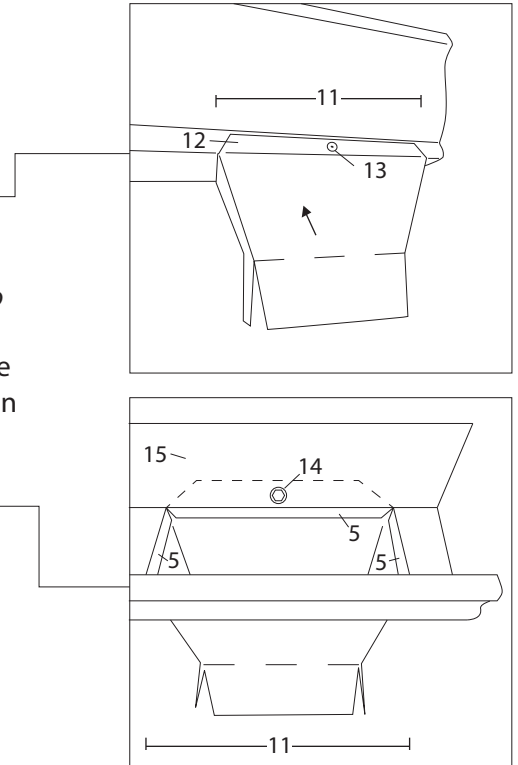

## Step 4 Final Sealants

- 4.1 - Apply sealant over front and back fasteners on inside of the gutter [16].
- 4.2 - Apply sealant on the inside of gutter at all four corners [17] keep sealant below gutter floor surface.  
Wide Mouth Installation is now complete
- 4.3 - Continue with your connection of downspout piping.

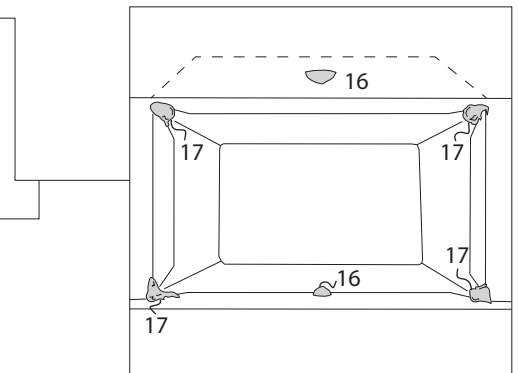

Downspouts pipe needs to be lowered (or cut back) from the gutter floor to allow for the added height of the Wide Mouth Outlet when installed between an existing gutter and downspout pipe.

2"x3" downspout - lower ~ 4"

3"x4" downspout - lower ~ 2"

## Questions?

Please contact Raindrop at any time.

Phone: **800-816-0199**

Email: **info@RaindropGutterGuard.com**

Website (Videos): **raindropgutterguard.com/videos**



www.RaindropGutterGuard.com